

LETTER	REVISION RECORD	DATE	APPRVD

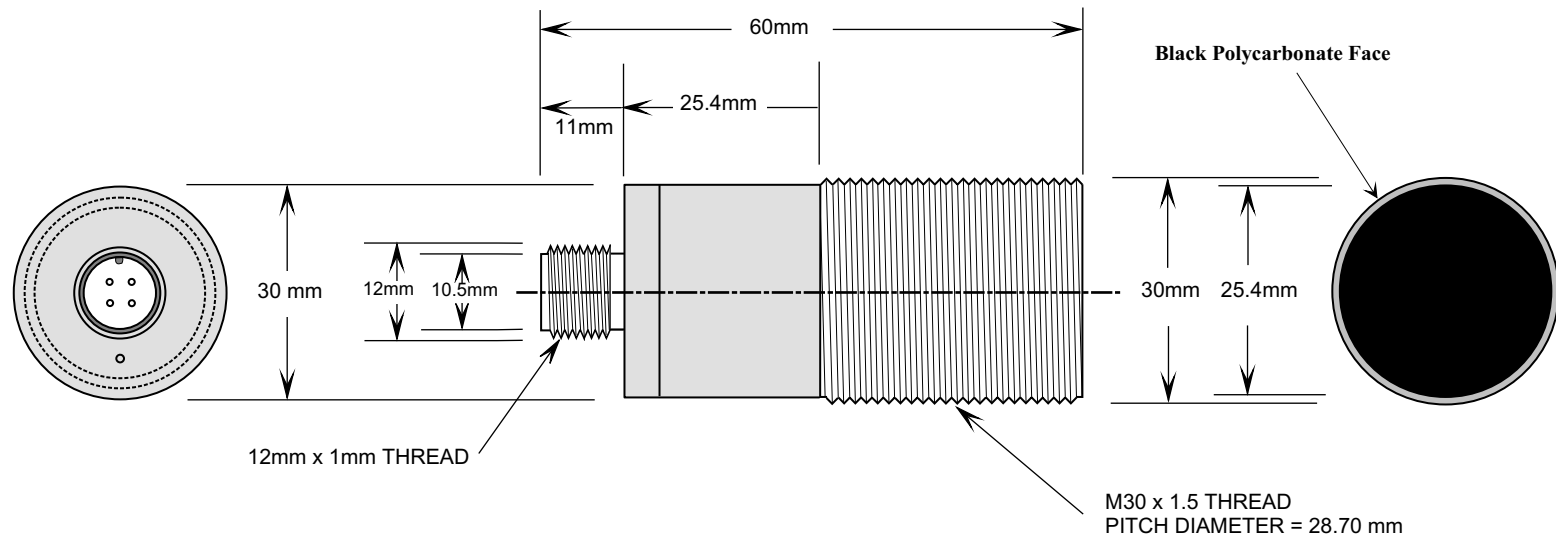

TOLERANCES UNLESS OTHERWISE SPECIFIED:

Metric:	Inches:
XX.X = ±0.25 mm	XX.XX = ±0.01"
XX.XX = ±0.125 mm	XX.XXX = ±0.005"
XX.XXX = ±0.050 mm	XX.XXXX = ±0.0020"
Angles = ±1 degree	

REMOVE ALL UNNECESSARY SHARP EDGES.
SURFACES TO BE CLEAN AND FREE OF DEFECTS.

DRAWN	DATE
CHECKED	
APPROVED	

PRIME CONTROLS, INC. Dayton, Ohio	
TITLE P70T30S PROBE PICTORIAL DRAWING	
SIZE	SHEET 1 of 1
A	SCALE 1 : 1
REV.	DWG. NO.