

OPERATING INSTRUCTIONS

MODEL LTC100 LEAK TEST CONTROLLER

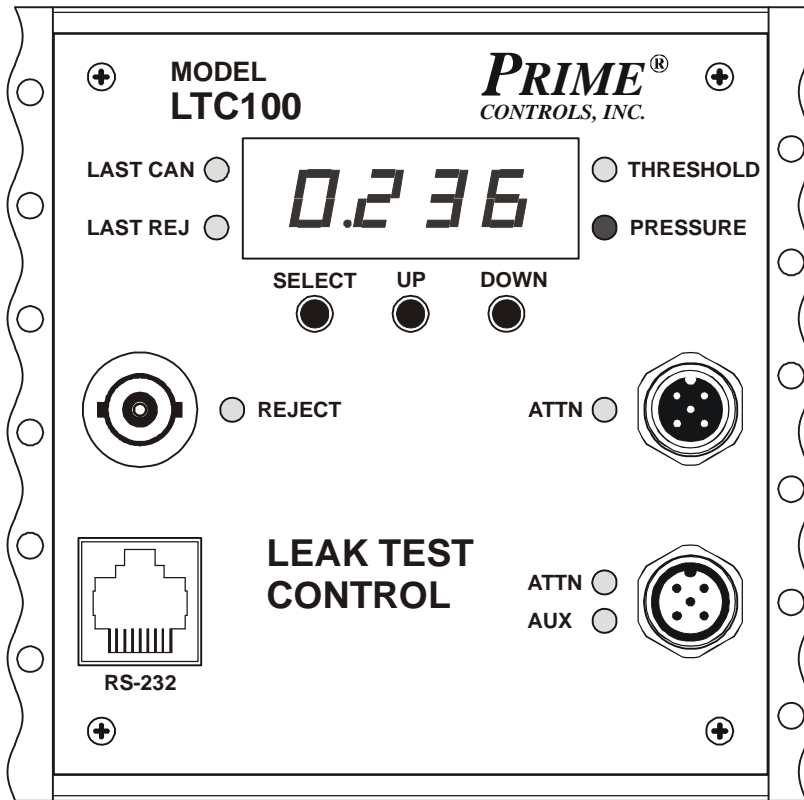

This document provides user information for the Prime Controls LTC100, a microcontroller-based module that, together with a TD10 module, provides an updated replacement for the TD-5 pressure sensor and associated pressure sensor amplifier.

The combination of TD10 and LTC100 provide functionality beyond what is offered by a TD-5 transducer and PS pressure sensor amplifier. The TD10 and LTC100 provide a digital readout of the quantified pressure from each test. These values may be used as a reference to set the test threshold, which is also entered as a digital value.

Description

The LTC100 comprises a single printed circuit board encased in a DIN rail carrier with a customized, painted aluminum cover. The module measures 4.2 inches wide by 4.125 inches high by 1.5 inches deep. The LTC100 connects to a TD10 through a five-conductor cable terminated in 12mm circular connectors and to the MD2 through a BNC connector to a coaxial cable. Power is supplied to the unit through a 12mm male circular connector. Information for the user is displayed on the front panel through a 4 digit numeric display and eight LED indicators.

Power Requirements

The LTC100 requires 24 volt DC power. The module itself draws approximately 200 mA. When connected to a TD10, the TD10 power passes through the LTC100 and total system power is approximately 240 mA at 24 volts.

External Connections

1. Five pole 12 mm circular male connector on the front panel for 24 volt power, common, logic signal in, logic signal out and logic signal out common.
 - Pin 1 – 24 Volt Power
 - Pin 2 – No connection
 - Pin 3 – Common
 - Pin 4 – Sourcing Logic Output (Reject)
 - Pin 5 – Logic Signal In
2. Five pole 12 mm female circular connector on the front panel for LTC100 to TD10 connection.
 - Pin 1 – 24 Volt Power Output
 - Pin 2 – RS-485 Signal Line
 - Pin 3 – Common
 - Pin 4 – RS-485 Signal Line
 - Pin 5 – Sourcing Logic Output
3. BNC connector on the front panel for LTC100 to MD2 connection.
4. RJ-45 female connector on front panel for optional data collection on a laptop.

User Interface

Displays and Indicators

The exposed user interface comprises a 4 digit, seven-segment display, three momentary pushbutton switches and 8 LED indicators.

The amber REJECT indicator adjacent to the coaxial connector reflects the state of the signal at the coaxial connection. The indicator is on when the REJECT signal is at zero volts and off when the reject signal is at negative 20 volts.

The amber ATTN indicator adjacent to the female 12 mm circular connector reflects the state of the ATTN signal (logic output) to the TD10. The indicator is on when the signal is at +22 volts and off when the signal is at zero volts. The ATTN signal on constitutes a LTC100 request for data from the TD10. Thus this indicator is always on when the TD10 is properly initialized and transferring pressure data to the LTC100.

Two amber indicators adjacent to the male 12 mm circular connector reflect the states of the incoming ATTN signal and the outgoing AUX signal. The ATTN signal is not used in the

normal application of the LTC100. The outgoing AUX signal is a sourcing REJECT signal that may be connected to a PLC. Whenever the incoming pressure is below the THRESHOLD pressure, this output is on (approx. 22 volts). Conversely, when the incoming pressure exceeds the THRESHOLD pressure, this output is off (zero volts).

Four indicators, two at each end of the digital display, indicate what is currently being displayed numerically. The values available for full-time display include:

PRESSURE:	The current pressure reading from the attached TD10 in units of psi.
THRESHOLD:	The reject threshold in units of psi., adjustable through the up and down pushbutton switches.
LAST REJECT:	The pressure reading from the last rejected container.
LAST CAN:	The pressure reading from the last pocket whose pressure value exceeded the Ct threshold value. This readout may be used to assess the integrity of pocket seals since leaky seals result in pressure readings that can be mistaken for leaky containers.

The numeric display also displays the parameter identifier and the parameter values when a parameter is being adjusted. When a parameter or its identifier are displaying, the four indicators near the numeric display are all off.

Changing the Displays

The leftmost pushbutton switch, labeled SELECT, allows the user to select what is currently displayed. Each press and release of the SELECT pushbutton causes the display to move to the next parameter. I.e., if the SELECT pushbutton is pressed and released when LAST CAN is displaying (upper left indicator on), the display begins displaying THRESHOLD pressure, the upper left indicator goes off and the upper right indicator turns on. Another press and release of the SELECT pushbutton results in the display of the current actual PRESSURE value from the TD10. A third press and release of the SELECT pushbutton causes the lower left indicator to turn on and the LAST REJECT peak value to be displayed. A fourth press and release of the SELECT pushbutton returns the display to LAST CAN and the upper left indicator is turned on.

The two pushbutton switches to the right of the SELECT pushbutton allow the user to adjust the threshold value. When the threshold value is displayed, pressing the UP pushbutton causes the value to increase slowly at first but increasing in rate until the UP pushbutton is released. Pressing the DOWN pushbutton causes the value to decrease slowly at first but increasing in rate until the DOWN pushbutton is released.

Adjusting Parameters

If the SELECT pushbutton is pressed and held for three seconds or longer, a parameter identifier (**Ct**, **Ot**, **Sc**) is displayed momentarily on the numeric display. When the SELECT pushbutton is released while a parameter id is displaying, the display changes to display the

actual value of the parameter associated with that identifier. While the parameter value is displaying, a press of the UP or DOWN pushbuttons causes the display to scroll forward or backward respectively to the next valid value for that parameter. When the correct value displays, releasing all pushbuttons for 5 seconds causes the latest displayed value to be installed as the active value. If no pushbuttons are pressed for a period of 5 seconds while the original value displays then the original value is retained and the display reverts back to displaying whatever was selected for display before the SELECT pushbutton pressed.

Three settings are adjustable through this method:

- Ct** – the container detect threshold (units of psi)
- Ot** – reject output minimum on-time (units of seconds)
- Sc** – the full-scale range of the attached TD10 (units of psi)

For example, press the SELECT pushbutton for three seconds to display **Ct**. Release the SELECT pushbutton while **Ct** is displaying to display the currently installed container detect threshold. Press the UP or DOWN pushbutton to change the value. The container detect threshold value can range from .000 psi to .999 psi though it is usually set somewhere between .010 and .100 psi. Release all pushbuttons for 5 seconds and the new value is installed and written to non-volatile memory and the display reverts back to whatever was displaying prior to the parameter change.

To display the **Ot** parameter identifier, continue to press the SELECT pushbutton after **Ct** appears and the display changes to **Ot**. Release the SELECT pushbutton and use the UP and DOWN pushbuttons to change the reject output one-shot time. This parameter can be set to any value within the range of 0 to 0.250 seconds. Release all pushbuttons for 5 seconds and the new time value is installed and written to non-volatile memory and the display reverts back to whatever was displaying prior to the parameter change.

To display the **Sc** parameter identifier, simply continue to press the SELECT pushbutton after **Ot** appears and the display changes to **Sc**. Release the SELECT pushbutton and use the UP and DOWN pushbuttons to change the full scale sensor range. Valid values are 1.500, 5.000 or 10.00. If the displayed value is 1.500, press the UP pushbutton to scroll the display forward to the value 5.000 or press of the DOWN pushbutton to scroll the display backward to the value 10.00. When the desired value displays and no pushbuttons are pressed for a period of 5 seconds, the newly selected value is installed and written to non-volatile memory and the display reverts back to displaying current pressure or whatever was selected for display prior to the three-second hold of the SELECT pushbutton.

Configuration Switches

A two-position DIP switch is hidden behind the front panel but accessible from the left end of the unit. The DIP switches are for configuring the certain features of the unit. The left switch selects the serial port baud rate as 38400 when off and 9600 when on. The right switch controls the polarity of the AUX output. When the right switch is off (up), the AUX output is off for reporting a leaker and on for reporting a non-leaker. Conversely, when the right switch is on (down) the AUX output turns on to report a leaker and off for a non-leaker.

Electrical Specifications

Power: 24 volts +/- 20% at 200 mA plus sensor power.
Max current through module (power to TD10 or other connected sensor): 5 Amps.

ATTN Input: Input impedance: 10K to common.
Max input voltage: 30 volts.
Off threshold (high to low): 2.9 volts.
On threshold (low to high): 4.0 volts.

ATTN Output: On voltage: V_{in} minus 1 volt.
Max current: 50 mA.
Overload protection: Self-resetting thermal fuse.
Transient protection: 30 volt transient absorber.

AUX (Alt. REJECT) Output: On voltage: V_{in} minus 1 volt.
Max current: 50 mA.
Overload protection: Self-resetting thermal fuse.
Transient protection: 30 volt transient absorber.

REJECT (MD2 Drive) Output: Accept voltage: -15 to -22 volts.
Off voltage: 0 volts.
Max current: 4 mA, self limiting.
Transient protection: 30 volt transient absorber.

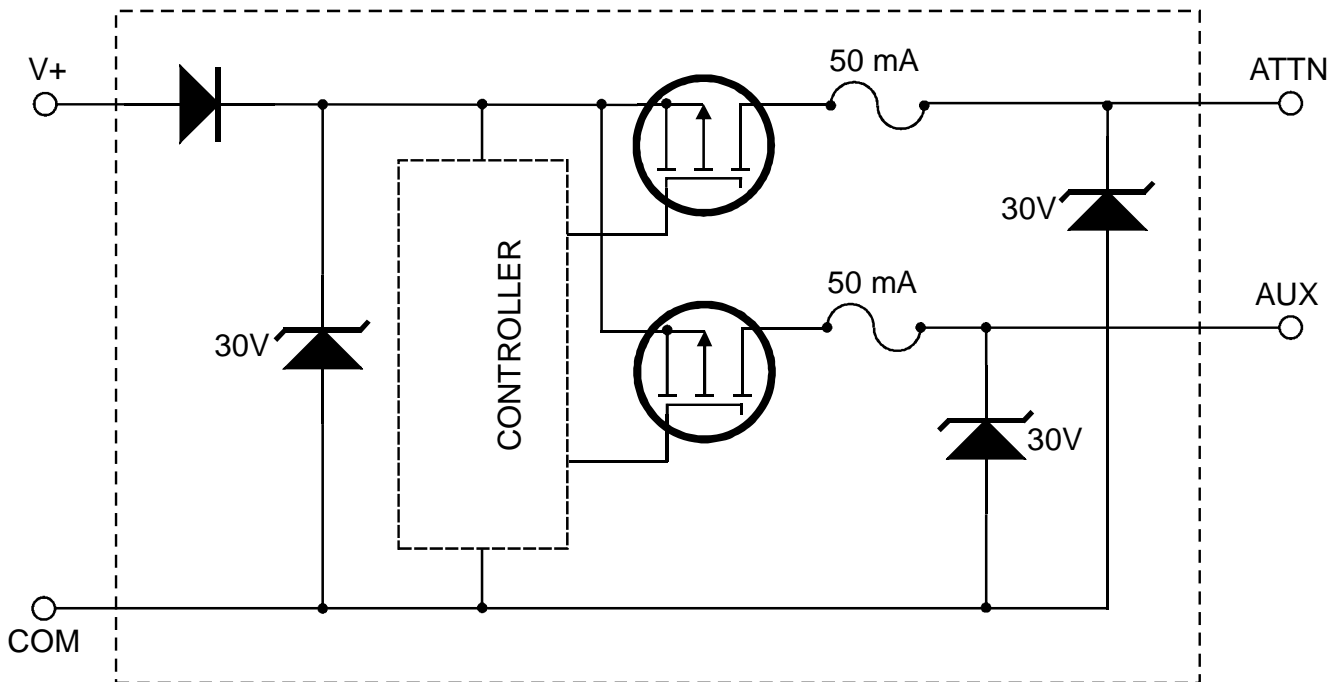

SOURCING OUTPUT DRIVER CIRCUITS