

# OPERATING INSTRUCTIONS

## MODEL DS1510 DOUBLE SHEET DETECTOR

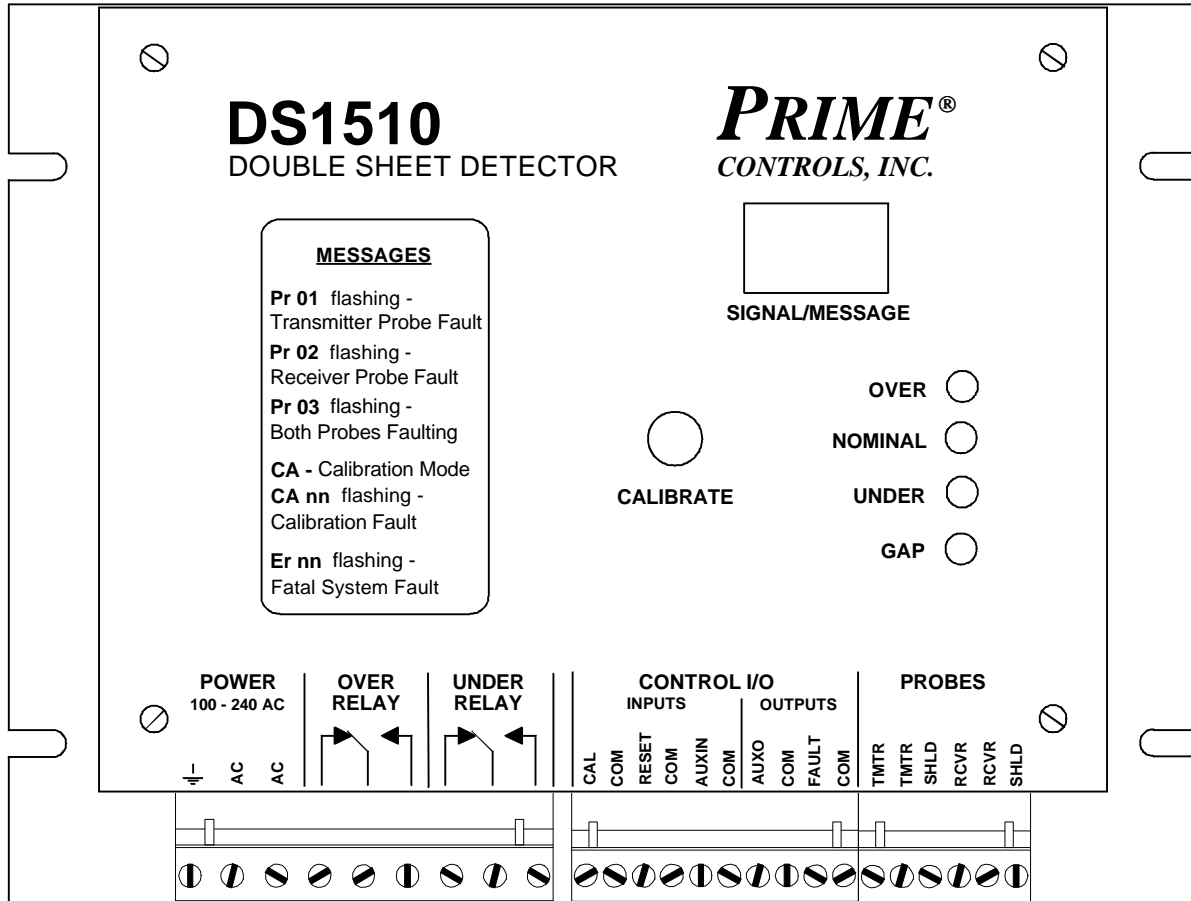

### DESCRIPTION

The Model DS1510 Double Metal Sheet Detector comprises a control module in a sheet metal housing with two probes to form a system that detects the thickness of metals passing between the probes. The thickness is reported via two form C relays as “nominal”, “over”, “under” or “nothing”. This system may be used on automatic sheet feeders where double or overlapped sheet material may jam or damage the receiving machine or ahead of roll forming equipment to insure lap welds do not damage the equipment. A double feed or overlap produces an output to stop the machine or signal the operator.

## DESCRIPTION

### System Features

The DS1510 is a highly flexible gauging system with a variety of features, some of which may be enabled or disabled through the positioning of DIP switches located beneath the control module cover. The various features include:

- Accommodates a family of probes allowing double detection on metals, from foil to heavy plate.
- Manual calibration on single and double thickness for all metals.
- Manual calibration on single thickness for steel.
- Automatic calibration on steel after material absence for a preset trigger time.
- Automatic nominal adjustment for roll stock of varying thickness.

Each of these features is described in greater detail later in this document.

### Control Module

The features of the control module include:

- Universal power input accommodates AC voltages from 100 to 240 volts.
- Removable terminal blocks for quick change-out of the control module.
- Separate form C relay outputs for independent reporting of OVER and UNDER conditions.
- LED indicators report the current gage states of NOTHING, UNDER, NOMINAL, and OVER.
- Automatic setup of system gain and operating parameters.
- External or front panel calibration through a contact closure or the front panel push-button switch.
- Two calibration memories that are selected through the AUXIN terminal. The memory contents are retained when power is removed from the unit.
- Latching OVER and UNDER outputs that are cleared by asserting the RESET input.
- A fast, open collector logic output that is ON for nominal readings and OFF for OVER or UNDER.
- An open collector FAULT output that may be connected to a master controller for monitoring fault and gauge-not-active conditions.
- Probe fault reporting on the two digit display warns of broken or disconnected probes or cables.

## DESCRIPTION

### **Control Module Indicators**

The function of the indicators and display on the DS1510 control module are described in the following paragraphs:

1. OVER LED is ON whenever the material thickness exceeds the calibrated nominal value by more than the set tolerance.
2. NOMINAL LED is ON whenever the received signal is within the specified tolerances, both over and under.
3. UNDER LED is ON whenever there is material between the probes but the material thinner than the calibrated nominal value by more than the set tolerance.
4. NOTHING LED is ON whenever the received signal goes beyond the measuring range of the instrument indicating an absence of material between the probes.
5. The OVER, NOMINAL, UNDER, and NOTHING LEDs flash in succession when the system is in calibrate mode.
6. Numeric Display indicates the level of the signal from the receiving probe and reports error or status conditions. During gauge operation the value on the display reflects the strength of the signal from the receiving probe. Thicker materials reduce the level of the signal reaching the receiving probe, consequently the displayed value is lower for thicker material and higher for thinner material.

### **Control Module Calibrate Push Button**

The push-button switch on the front panel of the control module serves to initiate the calibration process and to make adjustments to two numeric parameters, the automatic calibration trigger time (**Ct**), and the calibration delay time (**Cd**). The trigger time is adjustable from 0.1 minutes (6 seconds) to 25 minutes. The calibration delay is adjustable from 0 seconds to 9.9 seconds. The calibration delay is not available in units with firmware version numbers smaller than 3.9.

To initiate calibration, simply press the push button and release it within 3 seconds.

To view the current value of a parameter, press the push button and hold it for more than 3 seconds until the appropriate parameter identifier appears on the digital display. After the parameter identifier appears, release the push button and the current value of the parameter displays for 5 seconds. To retain the current value of the parameter, simply allow the 5 second display interval to elapse. The display reverts back to displaying signal strength.

To change the value of a parameter, press the push button and hold it for more than 3 seconds until the appropriate parameter identifier appears on the digital display. After the parameter identifier appears, release the push button and the current value of the parameter displays. Press the push button while the parameter is displaying and the value increments, first slowly then more rapidly. For more precise control of the value adjustment, simply tap the push button repeatedly until the desired value is displayed. All parameters roll back to their minimum values after reaching the maximum value. To retain the adjusted value of the parameter, simply allow the 5 second display interval to elapse. The display reverts back to displaying signal strength.

## DESCRIPTION

### Control Module Configuration Switches

An eight position DIP switch is located beneath the front cover on the main control circuit board to the left of the displays. These switches must be set to enable the features of the system that are appropriate to your application. Any time a switch setting is changed, the control module must be powered down and back up to install the change. The switches are read only at power up.

The functions of the switches are as follows:

Switches 1 & 2          Set the relay response time

<u>SW 1</u>	<u>SW 2</u>	<u>Effect</u>
OFF	OFF	Minimum delay
ON	OFF	100 millisecond delay
OFF	ON	500 millisecond delay
ON	ON	1 second delay

Switch 3:      OFF    Calibrate on single and double.  
                  ON      Calibrate on single only.

Switch 4:      OFF    Disable reference tracking.  
                  ON      Enable reference tracking.

Switch 5:      OFF    Probe and gap assessment occurs every time the system is powered up.  
                  ON      Probe and gap assessment is bypassed at power-up if the AUXIN input is high. If AUXIN is held low (connected to COM), probe and gap assessment occurs at power-up.

Switch 6:      OFF    Disable automatic calibration trigger.  
                  ON      Enable automatic calibration trigger.

Switch 7:                      Reserved for future expansion

Switch 8:      OFF:    The state of the relays for NOTHING in the gap is the same as for the NOMINAL state.  
                  ON:      The state of the relays for NOTHING in the gap, is OVER for the OVER relay and UNDER for the under relay.

### Control Module Polarity Jumpers

Each of the logic inputs (CAL, RESET, and AUXIN) to the DS1510 has associated with it a two position jumper plug located under the front cover and immediately behind its associated connector. These jumpers allow the inputs to be driven by a sinking or sourcing device. When the jumper plug is installed on the pins closest to the connector, the input is set up for a sourcing driver. When installed on the two pins farthest from the connector, the input is set up for a sinking driver, or dry contact between the input and COM.

Whether set for sinking or sourcing drivers, the input is active (ON) when the signal at the terminal is low (at COM).

## APPLICATION CONSIDERATIONS

### Choice of Probes

The DS1510 accommodates a number of Prime probes but is most often used with the P1000B, P70A, and P70CS probes. The P70A and P1000B probes are potted and completely sealed units with permanently attached cables. The P70CS probes are potted with connectors for easy removal. The same probe type is used for transmitter and receiver and is not polarized.

The table below provides rule of thumb information for probe selection.

Probe	Housing	Connection	Gap	Application
P1000B	Aluminum block	Cable	0.5" to 1.25"	0.060 and thicker
P70A	Threaded steel barrel	Cable	0.5" to 0.75"	0.004 to 0.060 steel
P70CS	Smooth stainless barrel	Connector	0.5" to 3.00"	0.004 to 0.060 steel

Probes with non-ferrous (aluminum and stainless steel) housings offer greater probe separation. Probes with steel housings are not affected by the material used for mounting. Probes with aluminum or stainless steel housings are affected by steel near them including mounting clamps. To realize maximum separation with the P70CS type units, the probes must be mounted in non-ferrous clamps, e.g. Nylatron or 303 stainless steel.

Prime offers a number of other probes that allow the DS1510 to be applied to a wide range of materials including magnesium, copper, stainless steel, and aluminum. For more information or assistance in selecting the appropriate probes, contact Prime Controls.

### Calibration Considerations

The DS1510 offers three different modes of calibration.

1. Manual calibration on single and double thickness material (two-hit calibration). In this mode, a sample of the nominal thickness is placed between the probes and the CAL push button or optional external cal switch is pressed. Then a second thickness (or multiples of the original) are placed between the probes and the CAL push button or external cal switch is again pressed. Calibration is complete unless the tolerance value must be adjusted.
2. Manual calibration on single thickness steel (single-hit calibration). In this mode, calibration can be initiated through a press of the CAL push button or an optional external cal switch prior to material entering the gap between the probes. The DS1510 enters a wait state until such time as material is fed between the probes. If the calibration delay parameter (**Cd**) is set to zero, calibration occurs within 100 milliseconds after material is sensed between the probes. For slow moving material, this delay can be increased (up to 9.9 seconds) to insure the material fully covers the probes before calibration occurs. See the **Control Module Calibrate Pushbutton** section earlier in this document for the parameter adjustment procedure.

## APPLICATION CONSIDERATIONS

3. Automatic calibration on single thickness steel. In this mode, calibration process is the same as for the manual single-hit calibration except that the calibration process can be initiated by the expiration of a timer within the DS1510. The timer (**Ct**) can be set to a value from 0.1 minute (6 seconds) to 25 minutes. When the DS1510 detects the absence of material between the probes, the timer count-down begins. If the count-down expires before material is sensed, the DS1510 enters calibration mode, waiting for material to be fed. If the calibration delay parameter (**Cd**) is set to zero, calibration occurs within 100 milliseconds after material is sensed between the probes. For slow moving material, this delay can be increased (up to 9.9 seconds) to insure the material fully covers the probes before calibration occurs. See the **Control Module Calibrate Pushbutton** section earlier in this document for the parameter adjustment procedure.

### NOTE

*The adjustable calibration delay parameter (**Cd**) is only available in systems with firmware version 3.9 or higher. Older systems can be upgraded at the factory for a nominal fee. See **Firmware Version** section later in this document for determining the firmware version of your system.*

The choice of calibration mode is application dependent since each mode has its advantages and disadvantages. Two-hit calibration offers the possibility of discriminating changes in metal thickness that are far less than 2 to 1 since the system is calibrated on samples of the thickness range to be discriminated.

### Relay Response Time

For most applications it is desirable that the OVER relay respond as quickly as possible. For thinner materials the response time is as fast as 3 milliseconds. For very thick metals the response time can be as long as 40 milliseconds.

If very fast response times are undesirable, the action of the relays can be delayed through the setting of DIP switches 1 and 2 as described under “Control Module Configuration Switches” earlier in this document.

### Tracking Nominal

The tracking nominal feature of the DS1510 (Switch 4 ON) is typically used on roll-fed material that varies in thickness over its length. The unit keeps a slow average of the thickness and gauges relative to the average rather than relative to a fixed nominal calibration value. The average is referred to as the tracking nominal. The tracking nominal is allowed to shift by as much as 50% in thickness in either direction from the calibrated nominal.

Whenever no material is sensed between the probes, the calibrated nominal is reinstated regardless of the final thickness of the previous material.

### **Gauge and Fault Monitoring**

The open collector FAULT output provides a means for monitoring the status of the DS1510 to insure that all material passing between the probes is checked for doubles. When the DS1510 controller detects a fault from a probe or from within the controller itself, the FAULT output turns OFF. Since the OFF state is the fault state, a loss of power at the DS1510 is, by default, reported as a fault.

With firmware Version 3.6 and later, the FAULT output also turns off whenever the controller is not in gauge mode, i.e. whenever the unit is in setup (**SU**) or calibration (**CA**) mode.

## INSTALLATION

The installation of the components of the DS1510 system is covered in the following paragraphs:

### DS1510 Control Module

The control board is designed to mount on the back panel of an electrical enclosure using the four mounting slots at the edges of the enclosure. The footprint is 8.25 inches (210 mm) by 6.25 inches (159 mm) with mounting slot locations on a rectangle 7.625 inches (194 mm) in the horizontal and 4.0 inches (102 mm) in the vertical. Insure that the mounting screws make good electrical contact between the module housing and the control enclosure back panel.

Avoid mounting locations with excessive heat and vibration.

### Probe Mounting

See instructions specific to the probes supplied with your system.

### Electrical Wiring

All wiring for the DS1510 connects to removable terminal blocks at the bottom of the control enclosure as described in the following paragraphs.

1. Connect 100 to 240 VAC, 50-60 Hz. power (15 watts) to the terminals labeled AC on the leftmost terminal block.
2. Connections to the control circuit of the machine are made through the OVER and UNDER form C relays as required. These relays are powered in the NOMINAL condition and the diagram on the DS1510 front panel reflects the NOMINAL state. As shipped from the factory, the NOTHING state places the relays in the same state as NOMINAL. DIP switch 8, beneath the cover of the DS1510, when ON, causes the NOTHING condition to place the OVER and UNDER relays in the over and under states simultaneously.
3. The shielded cables from the probes to the board should be run in conduit. The receiver probe is connected to terminals labeled RCVR on the rightmost terminal block and the transmitter probe to the terminals labeled TMTR on the same terminal block. Since the probes are non-polarized, the order of lead connection is not important and since the probes are identical, it does not matter which is the transmitter and which is the receiver. Connect the shield leads (drain wires) from the probe cables to the terminals labeled SHLD.
4. The OVER and UNDER relays may be operated in a "follower" mode or a "memory" mode depending upon the wiring of the RESET input. The operational modes and required connections are described below.
  - a) For "follower" mode, jumper RESET and COM together on the center terminal block. In this mode, when an OVER or UNDER condition occurs, the appropriate relay drops out, and the OVER or UNDER LED comes on. After the fault condition is corrected, the relay returns to the normally energized condition and the LED goes out. Automatic reset is normally selected to control the operation when the fault condition is automatically removed or the DS1510 is wired into the stop circuit of the machine.

## INSTALLATION AND SETUP

- b) For "latch" mode, wire the RESET and its associated COM terminal to the normally open contacts of a switch, relay, or controller output. In this mode, when a fault condition occurs, the relay drops out and the OVER or UNDER LED comes on. After the fault condition is corrected, the contact must be momentarily closed to energize the relay.
5. If gap assess bypass is not selected (SW 5 OFF), a switch or contact may be connected between AUXIN and COM to allow selection of two different calibration memories. Calibration data is stored in the memory that is selected at the time calibration occurs. Switching between calibration memories can be done at any time during DS1510 operation.
6. Optionally, the open collector FAULT output may be connected to a master system controller or to an indicator that warns of error conditions within the DS1510 system. This output is normally ON and turns OFF when an error condition is detected. Thus if the DS1510 loses power, the FAULT output reports an error condition by default.

With firmware Version 3.6 and later (see **Firmware Version** at the end of this document), the FAULT output turns OFF any time the DS1510 is not gauging the metal between the probes. In addition to error conditions, setup (**SU** on the display) and calibration (**CA** on the display) cause the fault output to turn OFF. This allows the unit to be monitored for non-gauge conditions.

## INITIAL SETUP

### Probe and Gap Assessment

The startup process of the DS1510 commences immediately after power up and includes several processes which are transparent to the user except for the sequence of characters that appear on the two digit display.

When the unit first powers up, the several different sequences of characters may appear on the two digit display depending upon which options are currently active. Typically, if probe gap assessment is not bypassed, the startup display sequence includes momentary flashing of **SU**, followed by momentary flashing of the probe identifier (**PR 15**, **PR70**, or **PR 1H.**), followed by momentary display of the selected memory identifier, e.g. **SL 01**. When probe gap assessment is bypassed (Switch 5 ON) the typical startup sequence includes momentary flashing of **SU by**, followed by momentary flashing of the probe identifier, e.g. **PR 70**. If the probes are faulty, disconnected, or cannot be identified, the controller flashes **PR 01** indefinitely.

After the probes have been identified, the sensing system is characterized and the spacing between the probes is determined. *For this assessment there must be no material between the probes.* Switch 5 ON causes the controller to bypass this assessment unless a contact is closed across AUXIN. However, *it is essential that this process be completed at least once after initial installation or whenever the physical arrangement of the probes is changed.* If assessment process is bypassed, the system flashes **SU by** on the two digit display during startup.

When the operating conditions have been established, the two digit readout displays a numeric value representing the receiver signal strength.

## CALIBRATION

The DS1510 offers three modes of calibration: 1) manual calibration on single and double material samples, 2) manual calibration on a single thickness material sample, and 3) automatic calibration on material coming between the probes after a period of not material between the probes.

### Calibration on Single and Double Thickness

For highest gauging precision, the double sheet detector must be calibrated on both a single and a double thickness of the material to be monitored, any time prior to running. This mode of calibration is selected when Switch 3 is OFF. Calibration values are retained even when power is removed from the DS1510. Depending upon selected options, the system can retain one or two different calibration settings in non-volatile memory.

1. Place a single sheet of the thickness to be gauged in the probe gap and press the CAL push button or close a contact across the external CAL input. If the calibration on single is accepted, the unit displays alternately "CA" and "2" indicating readiness to calibrate on a double thickness. If the calibration is not successful, the unit displays alternately "CE" and a number. Calibration may be attempted again immediately.
2. Place a double thickness of material to be gauged in the probe gap and press the CAL push button or close a contact across the external CAL input. If the calibration is successful, the unit resumes display of the signal strength. If the calibration is not successful, the unit displays alternately "CE" and a number. If this occurs, reinsert the single thickness and begin calibration again.

### Manual Calibration on Single Thickness

Manual calibration on single thickness is selected when Switch 3 is ON and Switch 6 is OFF. If you change the switch settings, be sure to power the unit down and back up to activate the new settings. The switches are read only at power-up.

When calibrate on single is selected, the calibration process may be triggered in two ways: by the press of the front panel push button, or by a 30 millisecond or longer contact closure between the external CAL input and COM.

Place a single sheet of the material to be gauged in the probe gap and press the CAL push button or close a contact across the external CAL input. If the calibration on single is accepted, the unit displays alternately "Fr" and a number indicating the frequency selected for operation. The displayed number has no meaning except for factory troubleshooting.

If the control senses no material between the probes when the CAL push button is pressed or the external CAL input is activated, it enters a wait state, flashing "CA" on the display until material is brought between the probes. An additional calibration delay can optionally be introduced through the calibration delay parameter (Cd). If not zero, this delay holds off the calibration process for the specified delay time after material comes between the probes to insure the material fully covers the probes during calibration. The additional delay may be required with slow-moving material. See the **Calibration Delay Time** section later in this document for the parameter adjustment procedure.

## CALIBRATION

Gauging commences immediately after calibration but only if the push button is released and the contact across CAL and COM is released. If either of the calibration initiating signals persists, the unit hangs in a wait state.

### **Automatic Calibration on Single Thickness**

Two switches must be properly set to enable automatic calibration. The system must be enabled for calibrate on single (Switch 3 ON) and automatic calibration must be enabled (Switch 6 ON). These switches must be set prior to powering the unit since they are read only at power-up.

Automatic calibration provides a time-based trigger that starts the calibration process. Whenever there is no material between the sensing probes for a time equal to or greater than the stored trigger interval (see **Auto-cal Trigger Time** later in this document), the DS1510 enters a wait state in preparation for calibration when material comes between the probes. The display flashes alternately “CA” and blank and the LEDs flash sequentially. The wait for material can be indefinite.

When material enters the gap between the probes, if the calibration delay parameter (**Cd**) is set to zero, calibration occurs within 100 milliseconds. For slow moving material, this delay can be increased (up to 9.9 seconds) to insure the material fully covers the probes before calibration occurs. With no programmed delay, typical calibration time is 300 milliseconds, total. See the **Calibration Delay Time** section later in this document for the parameter adjustment procedure.

#### *NOTE*

*The adjustable calibration delay parameter (**Cd**) is only available in systems with firmware version 3.9 or higher. Older systems can be upgraded at the factory for a nominal fee. See **Firmware Version** section later in this document for determining the firmware version of your system.*

If material comes between the probes before the trigger interval times out, the timer is reset to its programmed value.

When automatic calibration is enabled, the calibration process may still be initiated by a press of the CALIBRATE push button or a contact closure between CAL and COM. Actual calibration will begin only when material is sensed between the probes and the calibration delay has timed out..

### The Auto-cal Trigger Time

The trigger time interval for automatic calibration can be set by the operator through the CALIBRATE push button on the front panel of the DS1510 control unit. The interval is set in increments of 6 seconds (0.1 minutes) from 0 to 3 minutes, in increments of 12 seconds (0.2 minutes) from 3 to 5 minutes, in increments of 30 seconds (0.5 minutes) from 5 to 10 minutes, and in increments of 1 minute from 10 to 25 minutes. To set the trigger time interval, do the following:

1. Insure that the unit is not attempting to calibrate (no “CA” flashing on the digital display). If “CA” is flashing, place a piece of material between the probes and allow the calibration process to be completed. Calibration and time parameter adjustment are mutually exclusive processes.
2. Hold the CALIBRATE push button in for approximately 6 seconds or until “Ct” appears on the digital display. *WARNING: If the push button is released before 3 seconds, the DS1510 begins the calibration process.*
3. When “Ct” displays, release the push button and the trigger time interval is displayed on the digital readout. If the push button is not pressed again within 5 seconds, the display reverts back to displaying gauge signal strength and the current time value is retained.
4. Whenever the time interval is displaying, the push button may be pressed to increment the time to the desired value. The time value is incremented one resolution unit with every press and release of the push button. If the push button is held in, the value auto-increments at an ever increasing rate until the push button is released. The value increments up to a maximum of 25 minutes and then rolls back to 0.1 minutes.
5. When the time has been adjusted to the desired value, it displays for 5 seconds (assuming the push button is not pressed again) and then is accepted and saved in non-volatile memory. The display reverts back to displaying signal strength.

### Calibration Delay Time

The “**Cd**” parameter specifies the duration of a time delay that applies to single sample calibration, in both manual and automatic trigger modes. The sequencing is as follows:

1. Calibration is triggered, either manually or through trigger time-out.
2. The system waits indefinitely until metal is detected between the probes.
3. When metal is detected, the calibration delay time-out begins.
4. When the calibration delay has timed out, calibration begins.
5. When calibration is complete, gauging begins.

The calibration delay interval can be set to any value between 0.0 and 9.9 seconds. To set the calibration delay time, proceed as follows:

1. Insure that the unit is not attempting to calibrate (no “**CA**” flashing on the digital display). If “**CA**” is flashing, place a piece of material between the probes and allow the calibration process to be completed. Calibration and time parameter adjustment are mutually exclusive processes.
2. Hold the CALIBRATE push button in for approximately 3 seconds or until “**Cd**” appears on the digital display. If auto-cal is enabled, prior to displaying “**Cd**”, the DS1510 displays “**Ct**”. *WARNING: If the push button is released before 3 seconds, the DS1510 begins the calibration process.*
3. When “**Cd**” displays, release the push button and the calibration delay time interval is displayed in seconds on the digital readout. If the push button is not pressed again within 5 seconds, the display reverts back to displaying gauge signal strength and the current delay value is retained.
4. Whenever the time interval is displaying, the push button may be pressed to increment the time to the desired value. The time value is incremented one resolution unit with every press and release of the push button. If the push button is held in, the value auto-increments at an ever increasing rate until the push button is released. The value increments up to a maximum of 9.9 seconds and then rolls back to 0.0 seconds.
5. When the time has been adjusted to the desired value, it displays for 5 seconds (assuming the push button is not pressed again) and then is accepted and saved in non-volatile memory. The display reverts back to displaying signal strength.

## SPECIFICATIONS

### SPECIFICATIONS

#### Power Requirements

AC Power, 90 to 240 volts, 15 watts.

#### Logic Input Electrical Specifications

CAL, RESET, AUXIN:                    30 Volts maximum  
Upper switch threshold - 6.9 volts  
Lower switch threshold - 3.3 volts

When the internal jumper is installed for pull up to accommodate sinking drivers, the input is pulled to +15 volts through 4700 ohms. When the jumper is installed for pull down to accommodate sourcing drivers, the input is pulled to common through 4700 ohms.

#### Logic Output Electrical Specifications

AUXO, FAULT:                            NPN open collector, 100mA max., 50 volts max.

#### Output Relay Specifications

Maximum switched voltage:            380VAC  
Maximum switched current:            14 amps N.O., 5 amps N.C, AC resistive,  
8 amps DC  
Maximum switched power:              200W DC, 2,000VA AC.  
Minimum required contact load:        12V, 100 mA  
  
Expected mechanical life:               20 million operations  
Expected electrical life:                100,000 operations at 8 amps, 240VAC  
50,000 operations at 14 amps N.O., 5 amps N.C.,  
120VAC resistive  
30,000 operations at 7.2FLA, 45LRA, 120VAC  
10,000 operations at 5FLA, 30 LRA, 240VAC

**TROUBLESHOOTING**

Should trouble develop, proceed as follows:

1. If no indicators or displays are illuminated, check AC input power to the control module and the fuse located on the lower left of the chassis.
2. If the unit powers up but hangs displaying alternately “**Pr**” and “**01**”, the transmitter probe is either not connected, is shorted, or has an open in the wiring.
3. If the unit powers up, initializes and the LEDs indicate a response to the material in the gap but the relays do not switch, check that the relays are set to follow and not to latch (activate the RESET input to unlatch). For most installations, simply install jumpers between RESET and COM.
4. IF “**PR**” and “**01**” flash alternately on the display, check the transmitting probe for proper connection and continuity.
5. IF “**PR**” and “**02**” flash alternately on the display, check the receiving probe for proper connection and continuity.
6. IF “**PR**” and “**03**” flash alternately on the display, check both probes for proper connection and continuity.
7. If the unit flashes alternately “**Er**” and a numeric value between 1 and 8, perform the corrective action prescribed in the table below. If the error persists, consult the factory.

<u>“Er” Number</u>	<u>Fault Description</u>	<u>Correction</u>
01	Input shift register failure	Reset through power down
02	Output shift register failure	Reset through power down
03	Display shift register failure	Reset through power down
04	Control shift register failure	Reset through power down
05	System configuration data fault	Reset through power down
06	Gap assessment data fault	Execute gap assess procedure
07	Not used	
08	Processor CONFIG register fault	Call the factory

8. During manual calibration on single and double, errors may occur that are reported through the alternate display of “**CE**” and a numeric value of 1 or 2. These error codes have the following meanings:

<u>“CE” Number</u>	<u>Interpretation</u>
01	The single thickness material is too thin for the system as configure with the current probes.
02	The material is too thick for the system as configured with the current probes.

### **Firmware Version**

From time to time, as improvements are made to Prime products, the firmware controlling the units is revised. When setting a unit up or troubleshooting it may be necessary to determine the version number for the firmware installed in your unit. The version numbers begin with 1.0 and are incremented either by tenths (1.1, 1.2, etc.) for small revisions or by the integer digit (1.0, 2.0, etc.) for more significant revisions.

To determine the version of the firmware running in your unit, simply hold the calibration push button in as power is applied to the unit. The revision number will be displayed on the two-digit display alternately with the letters “Fr”. For example, Version 1.8 will flash alternately “Fr” and “1.8”.

For further information or service assistance, contact Prime Controls, Inc., 4551 Gateway Circle, Dayton, Ohio. Phone: (937) 435-8659. Mention model number and serial number.

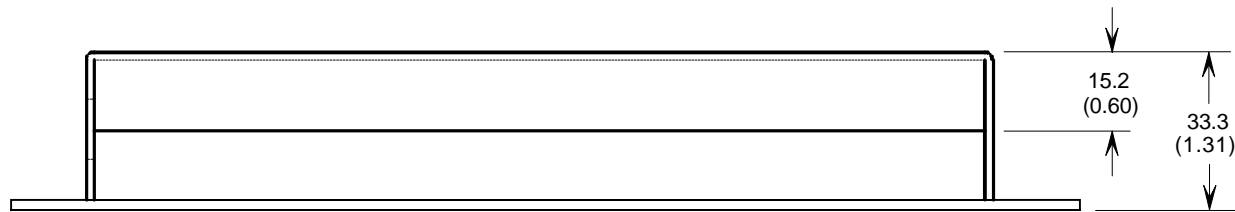
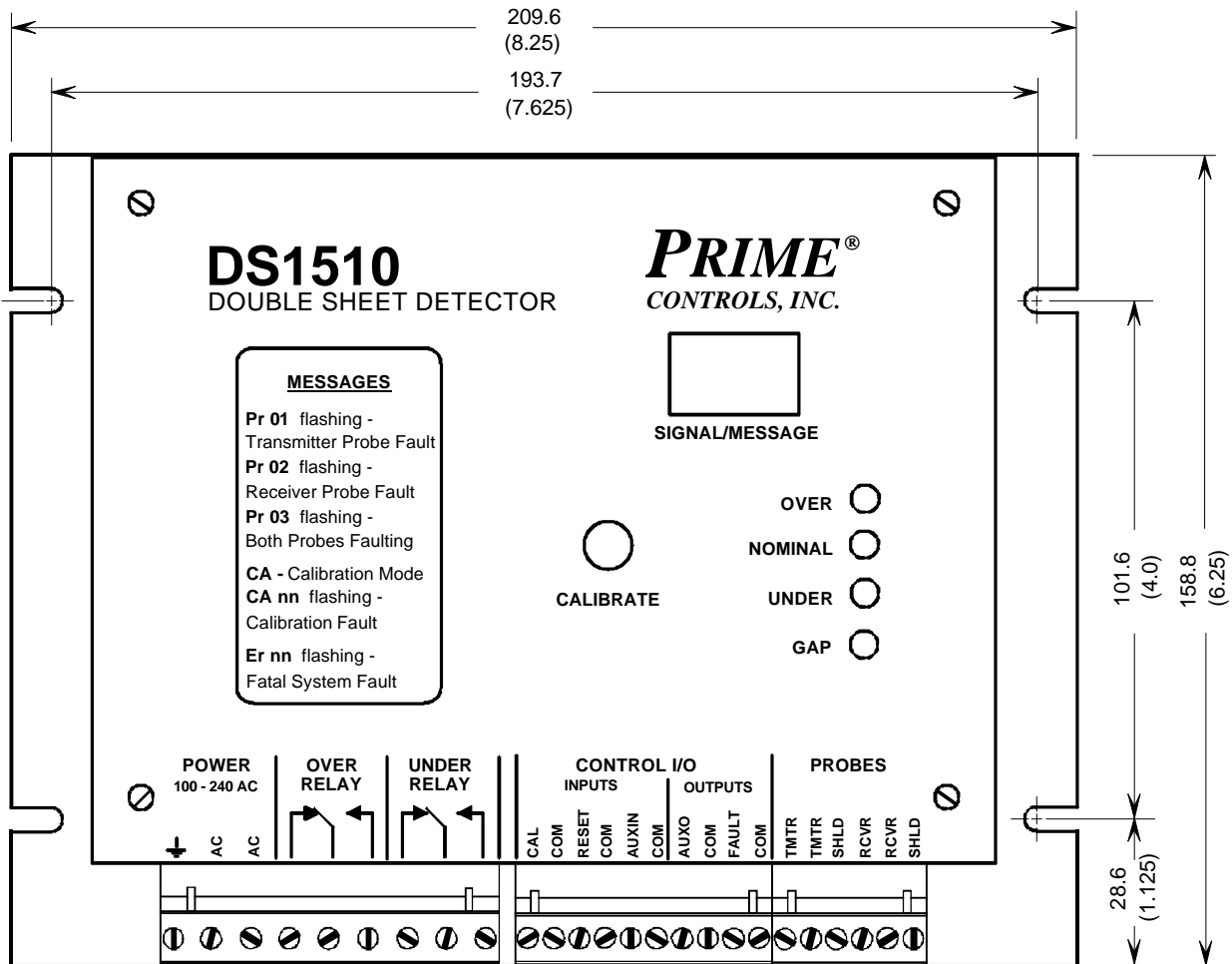

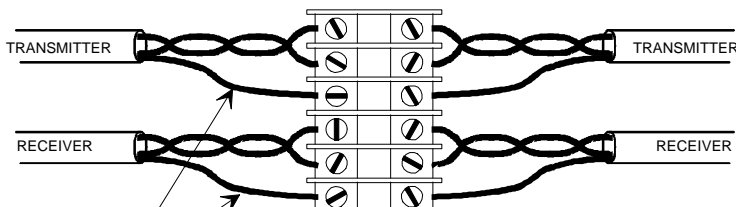
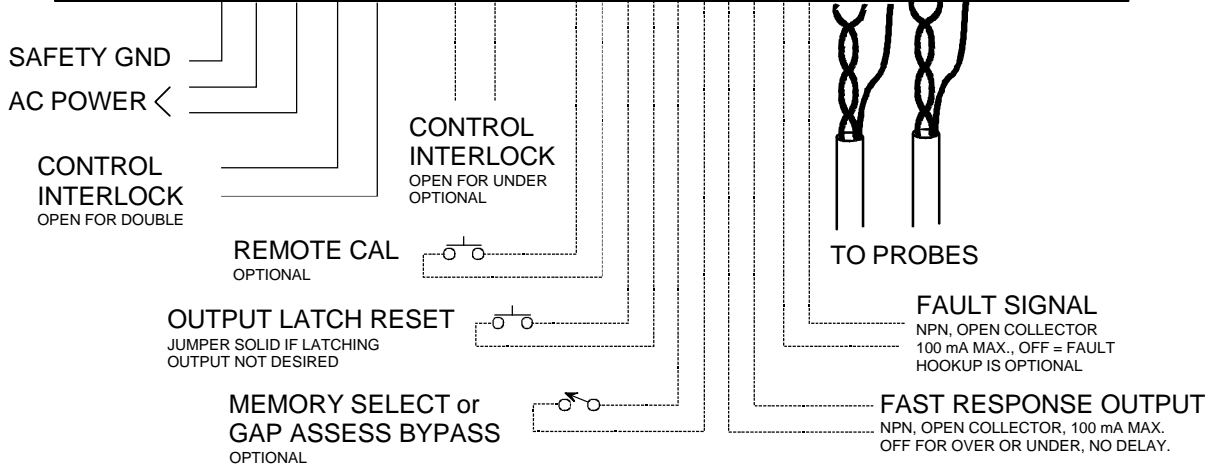
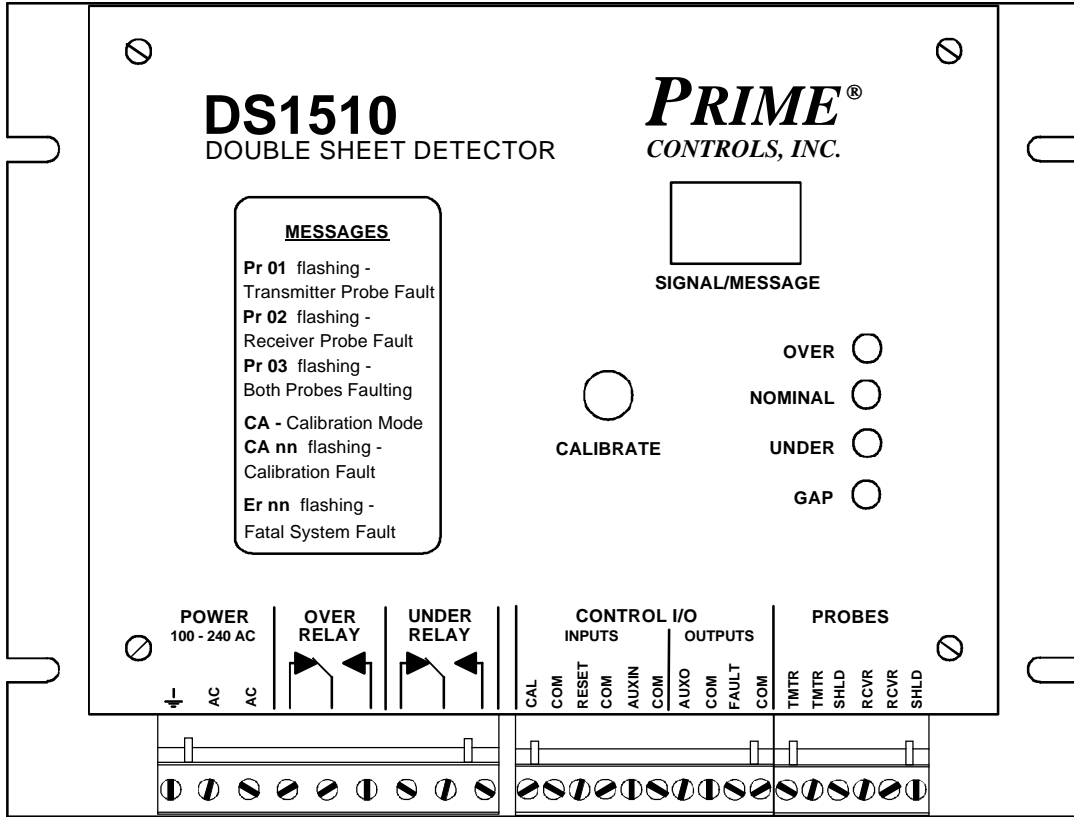

3. MAINTAIN INDEPENDENT SHIELDS
4. POSITION SHIELD TERMINALS BETWEEN TRANSMITTER AND RECEIVER SIGNAL TERMINALS

FOR MAXIMUM NOISE IMMUNITY, SPLICE OR TERMINATE CABLES ONLY WHEN ABSOLUTELY NECESSARY.

WHERE EXTENSION IS NECESSARY, USE BELDEN 8761 OR EQUIVALENT SHIELDED, TWISTED PAIR CABLE.

THE DS1510 IS DESIGNED TO PROVIDE HIGH COMMON MODE NOISE REJECTION. COMMON MODE REJECTION IS REALIZED MOST EFFECTIVELY WITH TWISTED PAIR CABLING.

## **LIMITATION AND EXCLUSION OF WARRANTIES**

All goods purchased from Prime Controls, Inc. shall be free from defects in materials, design and workmanship under normal conditions of use for one year from the date of shipment. THIS WARRANTY IS THE SOLE WARRANTY AND IS EXPRESSLY IN LIEU OF ALL OTHER WARRANTIES, EXPRESSED OR IMPLIED, INCLUDING BUT NOT LIMITED TO ANY IMPLIED WARRANTY OF MERCHANTABILITY OF FITNESS FOR A PARTICULAR PURPOSE. THE LIABILITY OF PRIME CONTROLS TO ANY PURCHASER SHALL BE LIMITED EXCLUSIVELY TO THE COST OF REPLACEMENT OR REPAIR OF DEFECTIVE PARTS, AND SHALL NOT INCLUDE LIABILITY FOR ANY DIRECT, CONSEQUENTIAL OR INCIDENTAL DAMAGES WHATSOEVER, WHETHER FORESEEN OR UNFORESEEN, INCLUDING BUT NOT LIMITED TO LOST PROFITS, LOST SALES, OR INJURY TO PERSONS OR PROPERTY. 9/25/97